

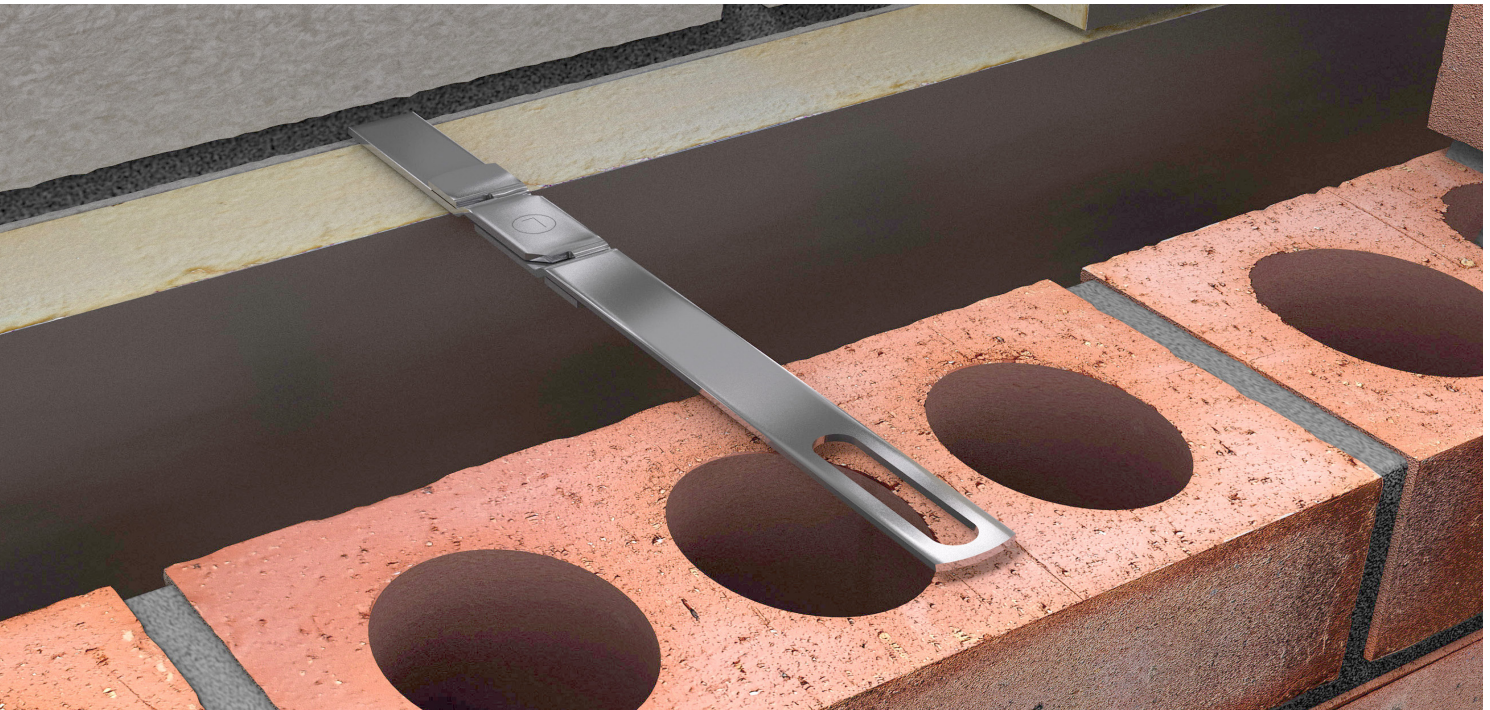

DATASHEET/DECLARATION OF PERFORMANCE

TTTTP TWO PART CAVITY WALL TIE

TEC/DD/1006



The unique “turn and lock” design of TecTies Two Part Tie provides a rigid connection between the two components and assists with the performance criteria for this type of tie. The ties are specifically designed for cavity widths exceeding 150mm where longer length ties are required.

The inner part which is 170mm long is built into the inner leaf of the cavity wall and the outer part is fixed into the outer leaf as it is built. The length of the outer part varies dependant upon the cavity width. An embedment of 75mm is required at each end. TecTies Two Part Ties are suitable for cavity widths up to 300mm and exceed the requirements for a Type 2 tie to BS EN 845-1:2013.

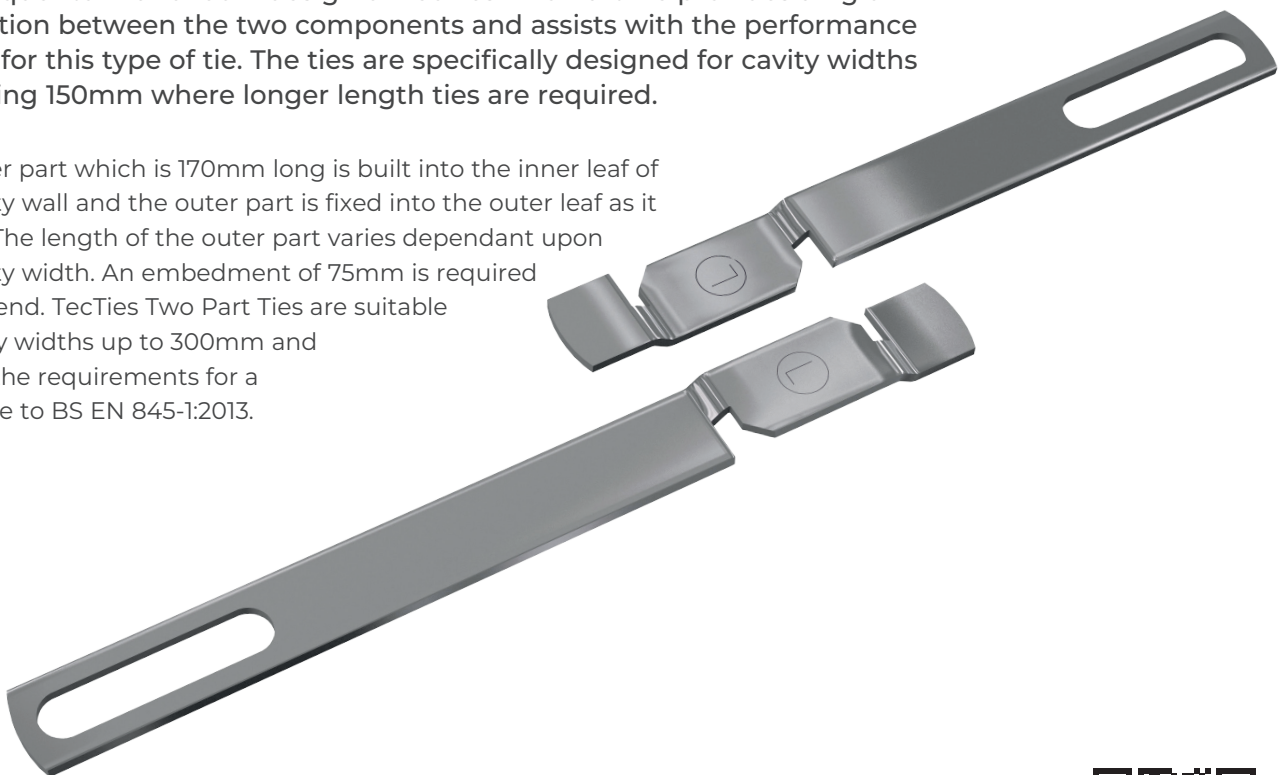

Check that you are using the most up to date version of this product information, **scan the QR code.**



TTTP PRODUCT ATTRIBUTES

Product Category	Cavity Wall Tie
Product Description	Two Part Cavity Wall Tie
Product Code	TTTP
Product Brand Name	Two Part Cavity Wall Tie

	TTTP150	TTTP175	TTTP200	TTTP225	TTTP250	TTTP275	TTTP300
Cavity Width	150mm using outer part length 200mm	175mm using outer part length 225mm	200mm using outer part length 250mm	225mm using outer part length 275mm	250mm using outer part length 300mm	275mm using outer part length 325mm	300mm using outer part length 350mm
Product Finish	Mill Finish						
Length	170mm inner + 200mm outer	170mm inner + 225mm outer	170mm inner + 250mm outer	170mm inner + 275mm outer	170mm inner + 300mm outer	170mm inner + 325mm outer	170mm inner + 350mm outer
Material Thickness	19x2.5mm	19x2.5mm	19x2.5mm	19x2.5mm	19x2.5mm	19x2.5mm	19x2.5mm
Material	Stainless Steel Grade 304						
Drip Function	Multi Drip						
Packaging Box / Bundle	Box						
Package Qty	Sold as individuals						
Tag / Label	Label						
Individual Weight	0.098 KG	0.105 KG	0.112 KG	0.119 KG	0.126 KG	0.133 KG	0.140 KG

Packaging Material 	Cardboard Box Widely Recyclable - Check with your local council guidelines Please visit the Environmental Commitment page here
Storage	Boxes of stainless steel wall ties to be stored indoors, Individual wall ties can be stored outdoors provided they are protected from contamination. Regular checks should be carried out to ensure packaging remains intact, ties remain clean, and there are no signs of corrosion, damage, or foreign material that could affect product quality or performance.
Safe Handling	Please visit the Handling Safety Information page here
Fire Rating	Euroclass A1

DECLARATION OF PERFORMANCE

TecTies Ltd hereby declares that Type 2 Two Part Tie TTTP are in conformity with the provisions of **ZA Annex of EN 845—1 : 2013+A1:2016**

Intended Use

Symmetrical Wall Tie Type 2 /Type B designed to connect two leaves of a cavity wall in masonry construction

Suitable for

See table below

Notified Body

Lucideon Limited, Queens Road, Penkhull, Stoke on Trent ST4 7LQ Tel. +44 (0)1782 764428

Notified Body Number 1289

Underwritten by TZUS – Prague

Notified Body Number 1020

The system of assessment and verification of constancy of performance for this construction product conforms to **System 3**

TTTP Essential Characteristics

	150mm	175mm	200mm	225mm	250mm	275mm	300mm
Cavity Width	150mm	175mm	200mm	225mm	250mm	275mm	300mm
Compressive Load Capacity	1525N	1525N	1525N	1525N	1525N	1525N	1525N
Tensile Load Capacity	2184N	2184N	2184N	2184N	2184N	2184N	2184N
Building Heights	Up to 15m						
Water Shedding Capability	Resistant						
Durability - Material Reference 3	Austenitic Stainless Steel						
Durability - Grade	304 18/8 comp. to BS EN 10088/1						
Embedment Depth	75mm						
Minimum Mortar Designation	(iv)						
Minimum Mortar Joint Width	10mm						
Conformity Assessment	UKCA+UKNI marked						
Testing	Tests were carried out by Lucideon Limited (UKAB No. 1289) in accordance with BS EN 846-5:2012: Methods of Test for Ancillary Components for Masonry – Part 5: Determination of Tensile and Compressive Load Capacity and Load Displacement Characteristics of Wall Ties (couplet test).						

All tested product information is available on request. Please contact us for more information.

CONSTRUCTION ORDER

- 1 Build the Inner Leaf
- 2 Position the Tie in mortar
[Install Insulation (if applicable)]
- 3 Build the Outer Leaf

Note: do not cut, bend or shape ties.

Images shown are using partial fill insulation.
Ties can also be used with full fill insulation.

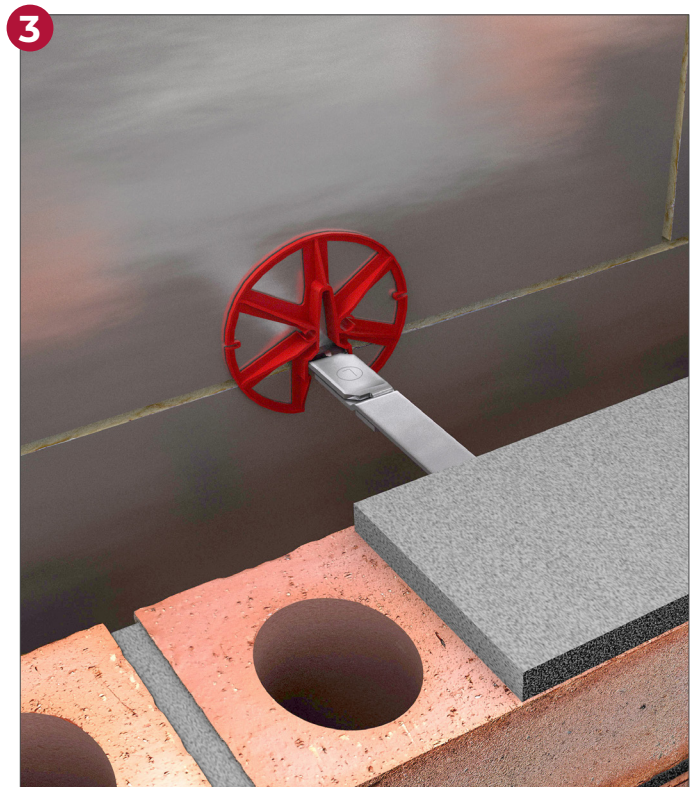
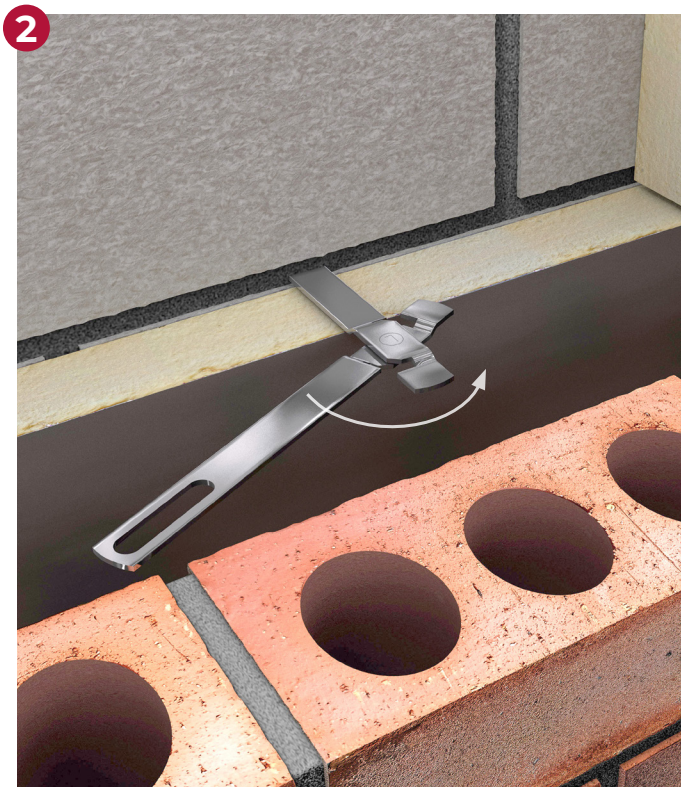

Installation

TecTies Limited products must be installed in accordance with the relevant product specifications, Declaration of Performance (DOP), and current building regulations to ensure full compliance with performance and safety requirements.

Only competent and trained personnel should carry out installation work. Working in accordance with the current HSE manual handling legislation.

Products must be checked prior to installation to confirm that they are undamaged, of the correct type, and suitable for the intended application. Any damaged or

non-conforming items must not be installed and should be reported immediately to the supplier or site supervisor.

Installation must be carried out using appropriate tools, equipment, and Personal Protective Equipment (PPE). Care should be taken when handling or fitting components with sharp edges or when working at height or in restricted areas.

All products must be installed in line with current building regulations, project specifications, and site safety procedures.

Once installation is complete, the work area should be checked to ensure all fixings are correctly secured, and waste materials are recycled or disposed of safely and responsibly.

INSTALLATION GUIDANCE FOR THE 2-PART TIE

When installing the 2-part tie, special attention must be given at corners and reveals.

During installation of the inner part (170 mm) at corners and reveals, ensure the correct orientation for the second part:

- The "L" marking must face upwards when the second part will be installed from the left-hand side.
- The "R" marking must face upwards when the second part will be installed from the right-hand side.

Correct orientation is essential. If the inner part is installed incorrectly, there may not be sufficient space to fit the second part. When installing the second part of the tie, ensure it is fully engaged, then apply pressure to rotate it into its final position.

Please see examples below.

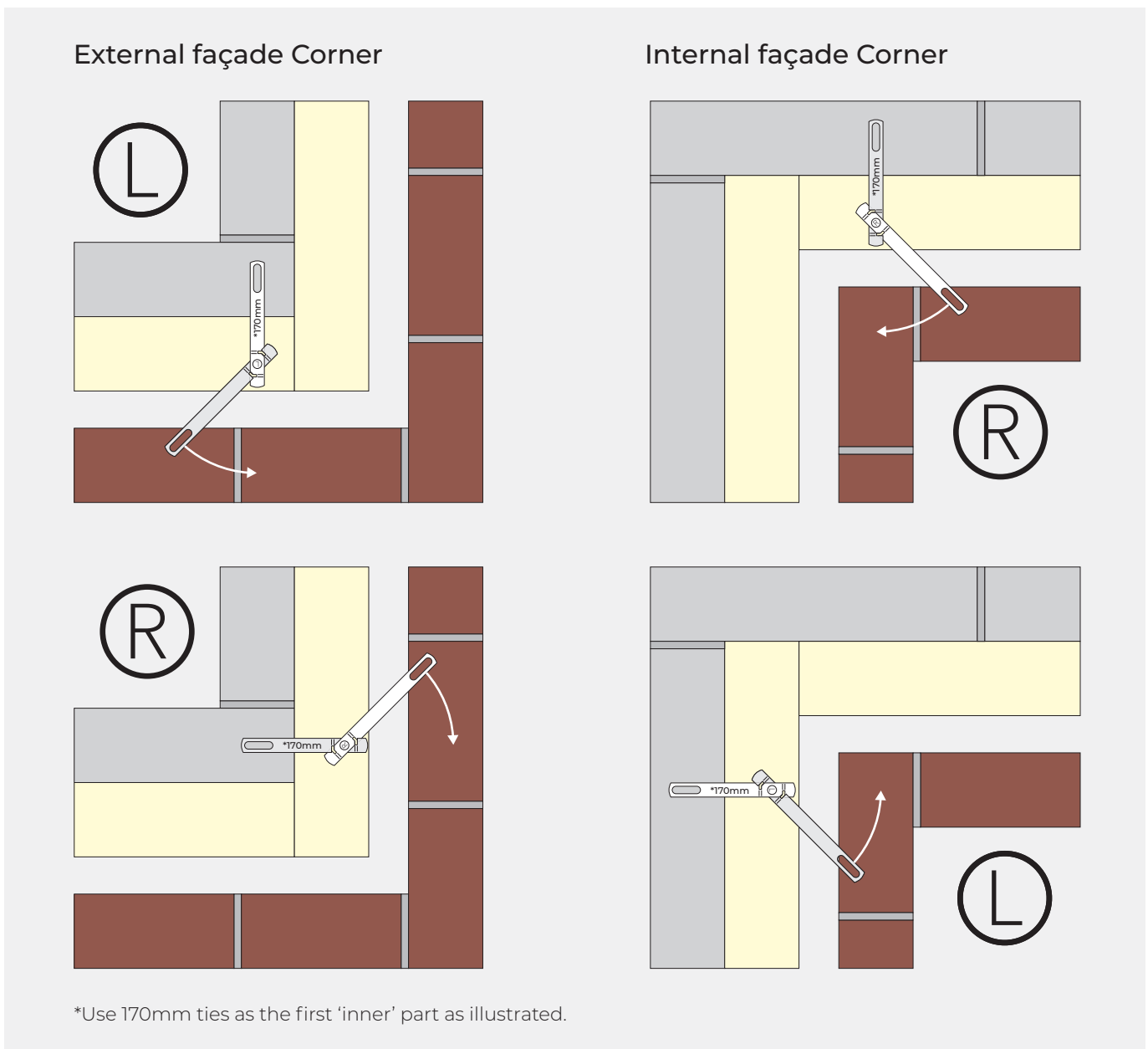

WALL TIE SPACING AND POSITIONING

In cavity walls where both leaves are 90mm or thicker there should be a minimum of 2.5 ties per square metre. The maximum horizontal spacing is 900mm and the maximum vertical spacing is 450mm, although this may be varied if required by the Building Regulations. The ties should be evenly distributed over the wall area, in a staggered pattern, except around openings.

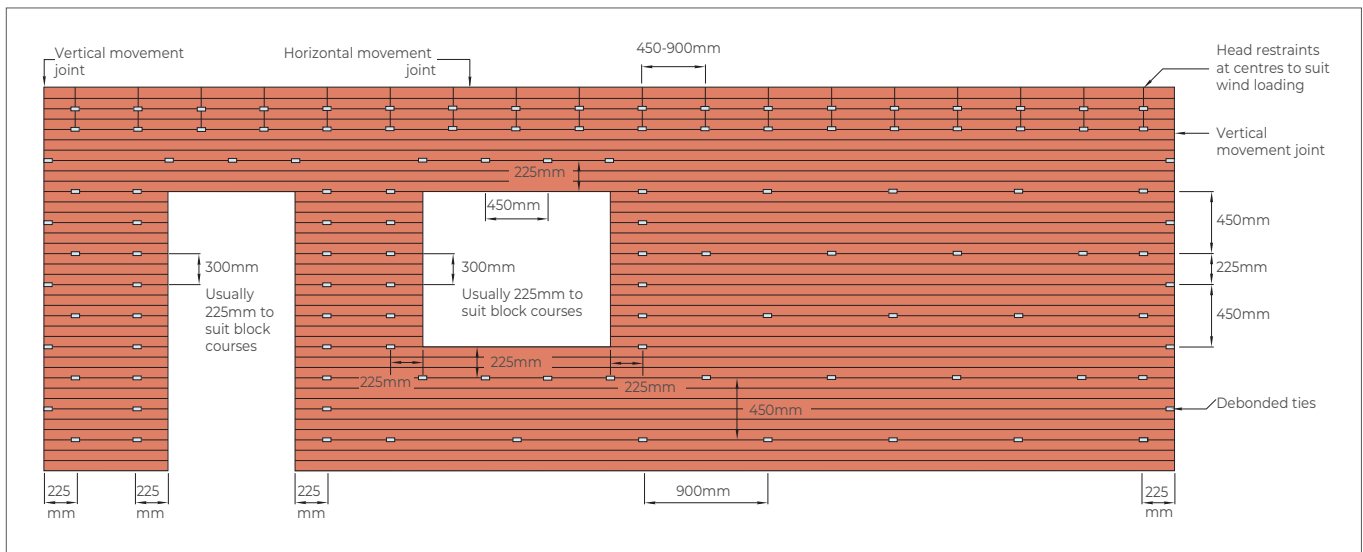

Standard spacing for cavity brickwork 900mm x 450mm centres in a staggered pattern (2.5 ties per square metre)

Change the wall tie pattern around openings such as windows, doors, roof verges, unreturned or unbonded edges and un-tied vertical movement joints. Here the vertical spacing is reduced to a maximum of 300mm and ties should not be more than 225mm from the edge of the opening. This often means there is a wall tie every course of blocks within 225mm of the opening. Spacing at vertical movement joints may be relaxed where the joint has a debonded tie.